

RAD750[®] 6U CompactPCI single-board computer

FEATURES AND CAPABILITIES

The 6U CompactPCI single-board computer, available in seven configurations, employs the PowerPC RAD750[®] microprocessor, the radiation-hardened version of the IBM PowerPC750 microprocessor. The companion Power PCI Bridge ASIC provides access to the memory and the PCI version 2.2 backplane bus.

Supports variable memory configurations:

SRAM:

- 16-MB standard
- Options from 4 MB to 48 MB and ECC
- Device-sparing

SUROM:

- 64 kB and ECC
- EEPROM for engineering units (256 kB to 1 MB)
- PROM for flight units (64 kB to 256 kB)

EEPROM:

- 4 MB and ECC

Software features

- Example startup ROM and VxWorks board-support package provided for all hardware configurations.
- Green Hills Software's INTEGRITY real-time operating system can serve as an alternate board support package.
- Hardware reference manuals and software user guide provided.
- Software developed for the RAD6000[®] processor is easily ported to RAD750 computers.
- All compilers currently available for the commercial PowerPC 750 microprocessor are fully compatible with the RAD750.
- Operating systems for PowerPC 750-based computers are easily ported to RAD750 computers. VxWorks and INTEGRITY operating systems are available.
- Virtutech offers a RAD750 simulator.

Form factor

- CompactPCI 6U (233 mm x 160 mm)
- CompactPCI 6U-220 (233mm x 220mm)
- Weight: 1000 to 1220 grams, varies with memory

Memory

- SRAM: 4 to 48 MB
- EEPROM: 4 MB

Radiation-hardness

- Total dose: >100 Krad (Si)
- SEU: 1.9 E-4 errors/card-day (90% W. C. GEO) varies with orbit
- Latchup-immune

Performance

- >260 Dhrystone 2.1 MIPS @ 132 MHz
- 4.3 SPECint95 4.6 SPECfp95 at 132 MHz

Power supply

- 5V ± 10% and 3.3V ± 5% (2.5V generated via onboard regulator)

Power dissipation

- 11 to 14W

Rail temperature range

- -28°C to +70°C

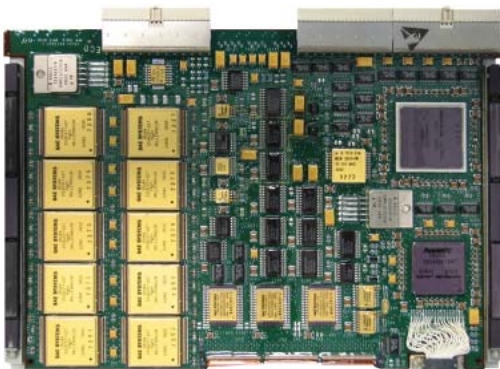

RAD750 6U FLEXIBLE ARCHITECTURE

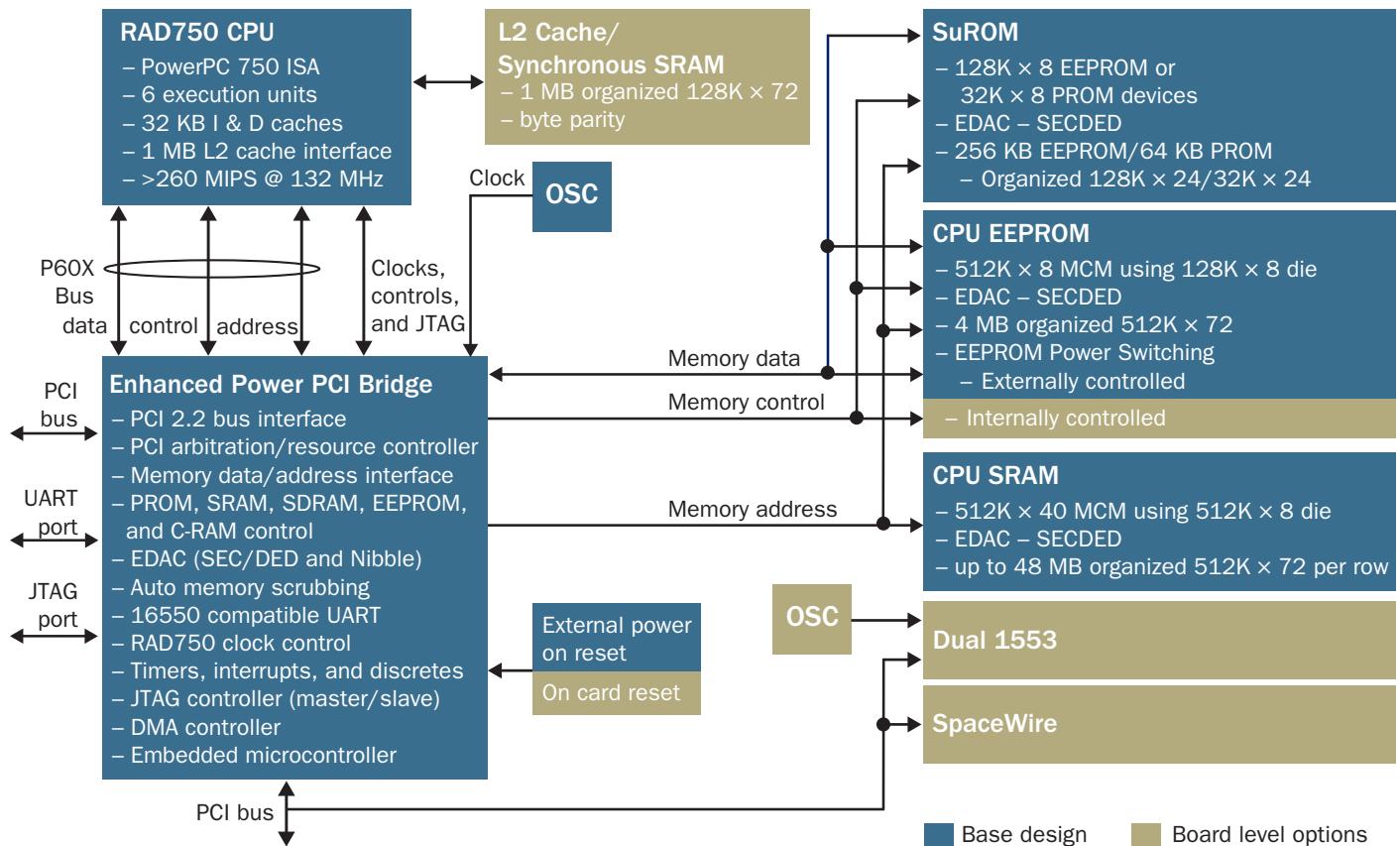

RAD750 FAMILY OF PRODUCTS

RAD750® radiation-hardened PowerPC microprocessor
 RAD750® 6U CompactPCI single-board computer
 RAD750® 6U CompactPCI extended single-board computer

RAD750® 3U CompactPCI single-board computer
 RAD750® space computers Virtutech Simics virtual platform
 RAD750® custom single-board computers

FOR MORE INFORMATION, CONTACT:

BAE Systems
 9300 Wellington Road
 Manassas, Virginia 20110-4122
 Telephone 1 800 RAD750A or 1 866 530 8104
 www.baesystems.com/sse

This document gives only a general description of the product(s) or services and, except where expressly provided otherwise, shall not form any part of any contract. From time to time, changes may be made in the products or the conditions of supply.

©2008 BAE Systems